

two-piece, »FUTURA-mini« series

Two-piece service units with excellent flow rates in modern design.  
Diaphragm pressure regulator with secondary ventilation.

Input pressure	1.5 - 12 bar
Temperature range	-10 °C to 50 °C
Medium	Compressed air, neutral gases
Housing	PA66 GF60
Connecting thread	Plastic
Filter element	Cellpor (PE)
Filter rating	5 µm
Sight dome	PC
Sealant	NBR
Diaphragms	NBR
Flow rate	800 l/min
Flow rate measurement	At P <sub>1</sub> = 10 bar, P <sub>2</sub> = 6.3 bar and pressure drop Δ <sub>p</sub> = 1 bar

### Service unit, 2-piece with metal bowl and compact pressure gauge

Art. No.	Type No.	Thread	Size	Control range bar	Pressure gauge display bar	Condensate drain
142478	FUM 601 M-4-KM	G 1/4	0	0.1 - 4	0 - 6	Semi-automatic
142479	FUM 601 M-8-KM	G 1/4	0	0.5 - 8	0 - 12	Semi-automatic
142480	FUM 601 M-10-KM	G 1/4	0	0.5 - 10	0 - 12	Semi-automatic
142508	FUM 611 M-4-KM	G 1/4	0	0.1 - 4	0 - 6	Fully-automatic
142509	FUM 611 M-8-KM	G 1/4	0	0.5 - 8	0 - 12	Fully-automatic
142510	FUM 611 M-10-KM	G 1/4	0	0.5 - 10	0 - 12	Fully-automatic

## Accessories / spare parts

Art. No.	Type No.	Description
143102	R 11-55 K	Panel nut M30x1.5
143105	H 848	Mounting bracket, incl. 2 screws
143106	H 849	Mounting bracket for thread for panel mounting
143010	WKM 100	Coupling package for wall mounting incl. 2 screws and O-ring
143022	KPM 100	Coupling package incl. 2 screws and O-ring
100134	611.6.905	Filter element 5 µm, Cellpor
100357	640/1-HA	Polycarbonate bowl (filter)
100383	740/01	Polycarbonate bowl (lubricator)
152077	WK 100-14	Wall bracket with connection thread G 1/4
143144	640/11-A-NC	Metal container, Fully-automatic (NC)
152961	655.6.901	Automatic drain valve, usually closed (NC)
100361	KS 11 F-A	Polycarbonate bowl with automatic draining
143142	KS 11 F-A-NC	Polycarbonate container, Fully-automatic (NC)
100359	641/11-HA	Metal bowl with semi-automatic drain
100391	740/11	Metal bowl (lubricator)
100360	640/11-A	Metal bowl with automatic drain valve
118137	302.4.9	O-ring 30x2 mm for container
143131	1811.3.904	Wheel 0.1 - 4 bar
143136	1811.5.904	Pressure spring 0 - 4 bar
143140	22.7010M.4	Spare parts for filter regulator/regulator
100362	655.6.900	Automatic drain valve
100214	901.7.990	Sight dome, polycarbonate
143132	1811.3.908	Wheel 0.5 - 8 bar
143138	1811.5.908	Pressure spring 0 - 8 bar
117242	1811.3.910	Wheel 0.5 - 10 bar
117251	1811.5.910	Pressure spring 0 - 10 bar
152301	KM6	Compact pressure gauge 0 - 6 bar
152298	KM12	Compact pressure gauge 0 - 12 bar

Semi-automatic:

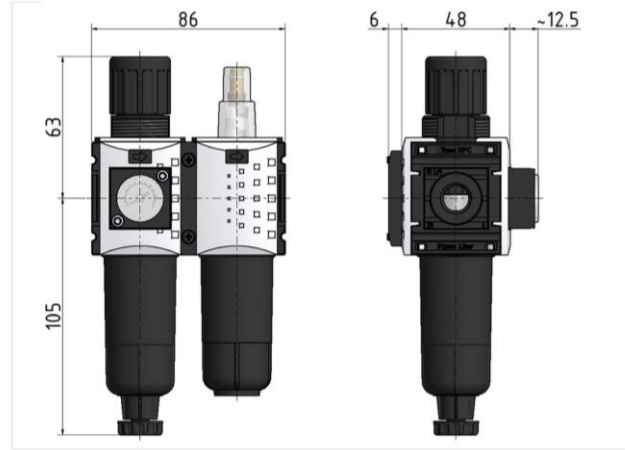

Fully-automatic:

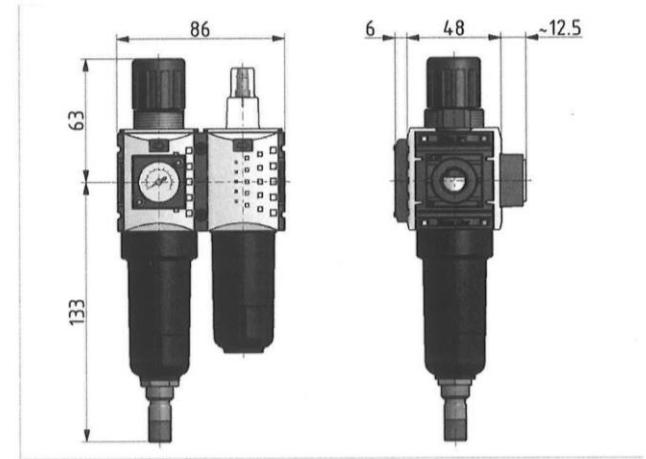

flow characteristic

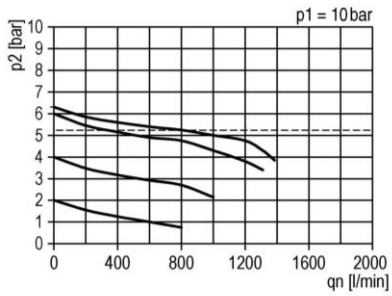

pressure characteristic

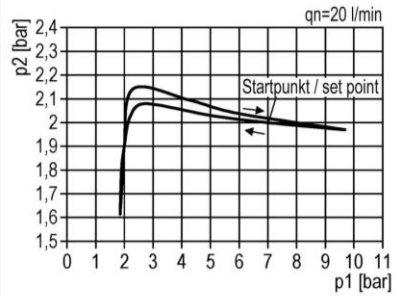

lubricator operating limit

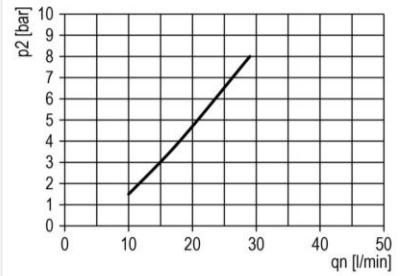

symbol

